

WIGAN i00

WALTHAM HOUSE LANE,
WIGAN WN5 0JZ

NEW DISTRIBUTION/ INDUSTRIAL UNIT

102,077 SQ FT
(9,483 SQ M)



SUSTAINABLE
DESIGN

AVAILABLE
NOW



1 MVA
POWER SUPPLY

MARKET LEADING SPACE

Wigan 100 is in an excellent strategic location for companies looking to relocate or expand their business. The local area is home to numerous industrial and logistics occupiers including Heinz, Makita and Arrow XL.

The unit comprises 102,077 sq ft and has been designed to an enhanced specification that includes various sustainable initiatives that are of critical importance to our stakeholders.

The Unit has been finished to the highest standards and occupiers can expect a best-in-class facility for their future operations. The unit has achieved BREEAM "Excellent" accreditation.

Detailed planning consent was awarded in January 2025 and construction has completed for immediate occupation.



IT'S ALL IN THE DETAILS

ENHANCED SPECIFICATION



FIBRE CONNECTIVITY



28 CYCLE SPACES



BREEAM "EXCELLENT"



EPC "A" RATING



10 EV CHARGING POINTS

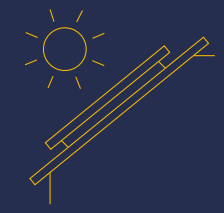

ROOF DESIGNED FOR PV PANELS



SUSTAINABLE MATERIALS



ENERGY EFFICIENT HEATING, COOLING, AND LIGHTING

SPECIFICATION



8 DOCK LEVEL LOADING DOORS INC. 2 EURO DOCKS



2 LEVEL ACCESS LOADING DOORS



50 KN/m² FLOOR LOADING



1 MVA POWER SUPPLY

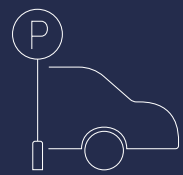

94 CAR PARKING SPACES



SECURE YARD UP TO 42M DEPTH

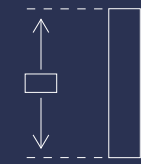

12M CLEAR INTERNAL HEIGHT



GRADE A OPEN PLAN FIRST FLOOR OFFICES

ACCOMMODATION

	SQ FT	SQ M
WAREHOUSE	95,861	8,905
FIRST FLOOR OFFICES	5,005	465
GROUND FLOOR CORE	888	82
GROUND FLOOR FIRE ESCAPE	323	30
TOTAL GIA	102,077	9,483

Subject to final measurement.

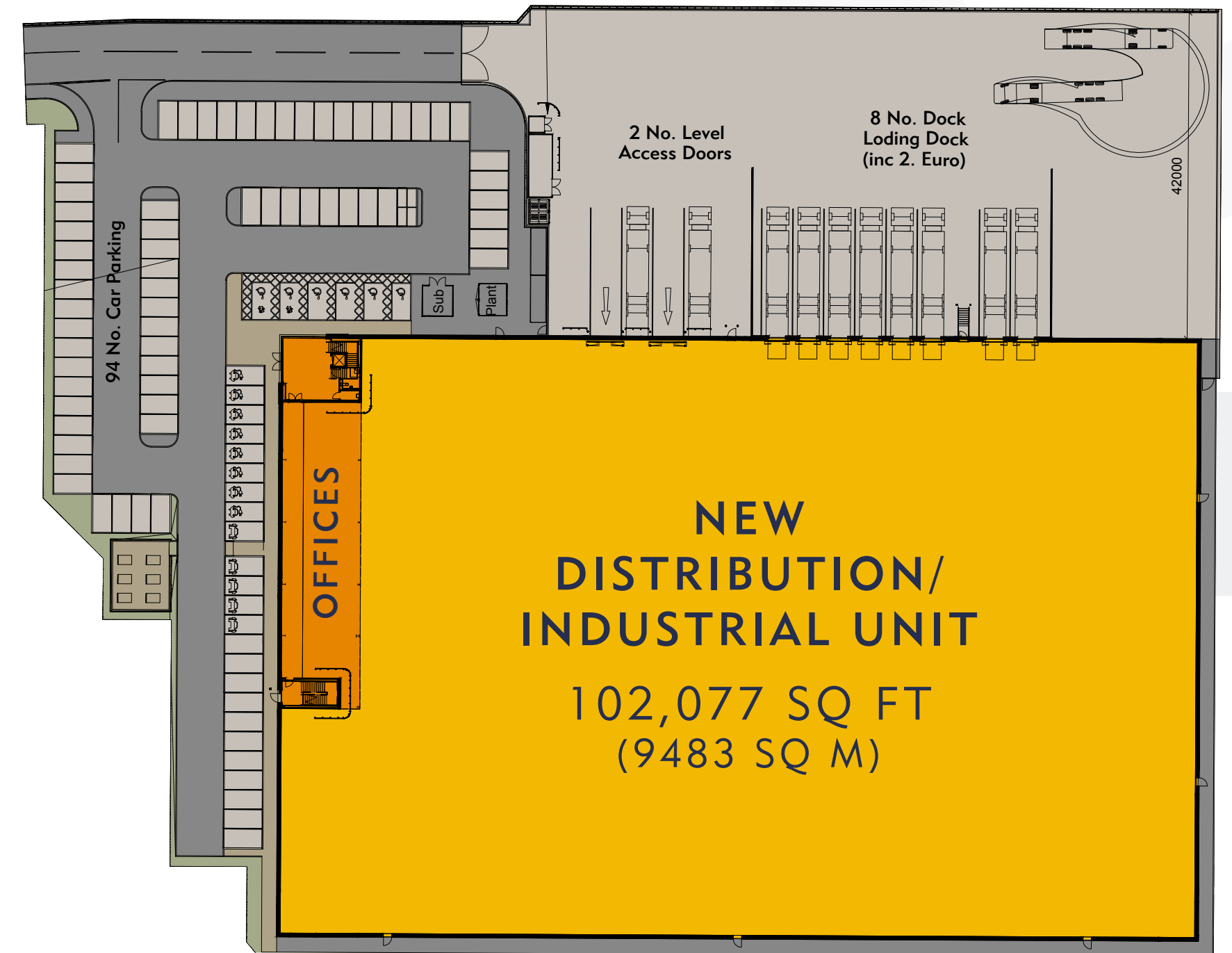

RACKING LAYOUT (MAXIMUM)

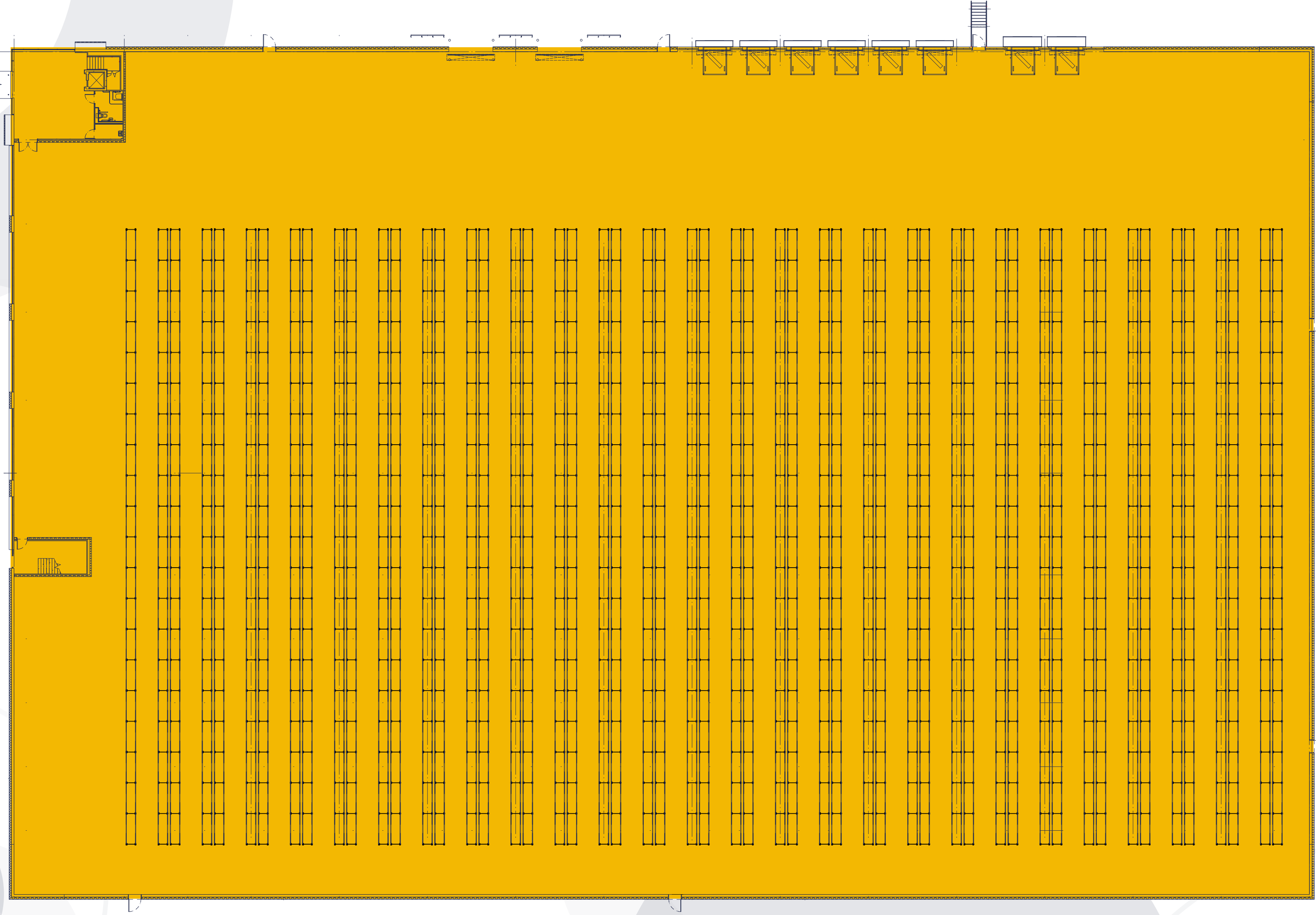

VNA PALLET RACKING LAYOUT
MINIMUM AISLE 2M

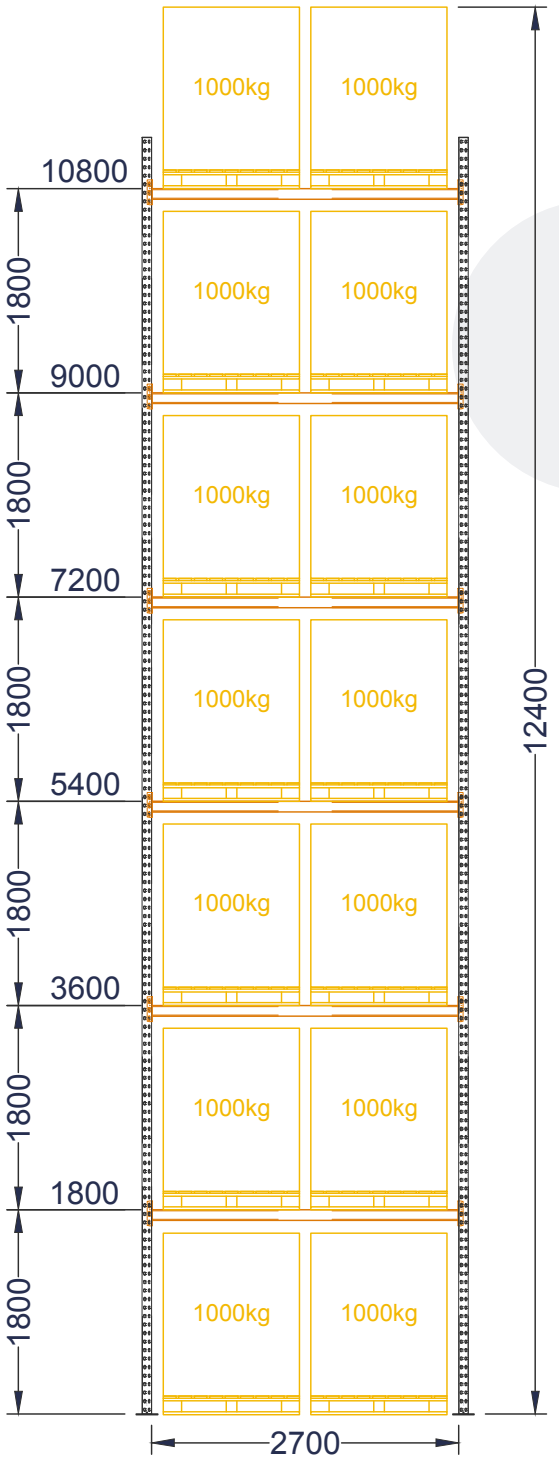

TYPICAL BAY ELEVATION

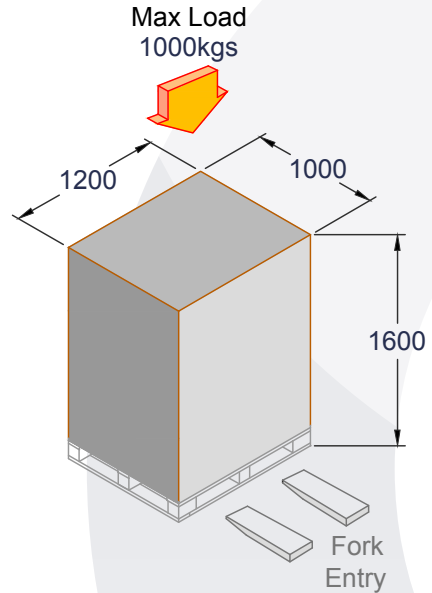

PALLET COUNT - 14,840
(MINUS POSITIONS LOST TO
BUILDING COLUMNS)

STRENGTH IN NUMBERS



33.2%

33.2% of workforce age in Wigan are well educated at NVQ level 4 or equivalent.



75.8%

Approximately 158,100 persons of working age in catchment area.



LOWER MEDIAN

Wigan also have a lower median weekly and annual pay in comparison to the north west and England averages.



£28,792

Gross Annual Pay In Wigan, compared to an average of £37,430 in UK.



3.5%

Unemployment rate in 2023/24 in Wigan was 3.5% - a lower unemployment rate than the Northwest at 4.1%, and Great Britain at 3.7%.

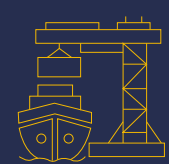

8.7%

8.7% of all employment in Wigan are process, plant and machine operatives (compared to 5.5% in Great Britain).

QUALIFICATIONS

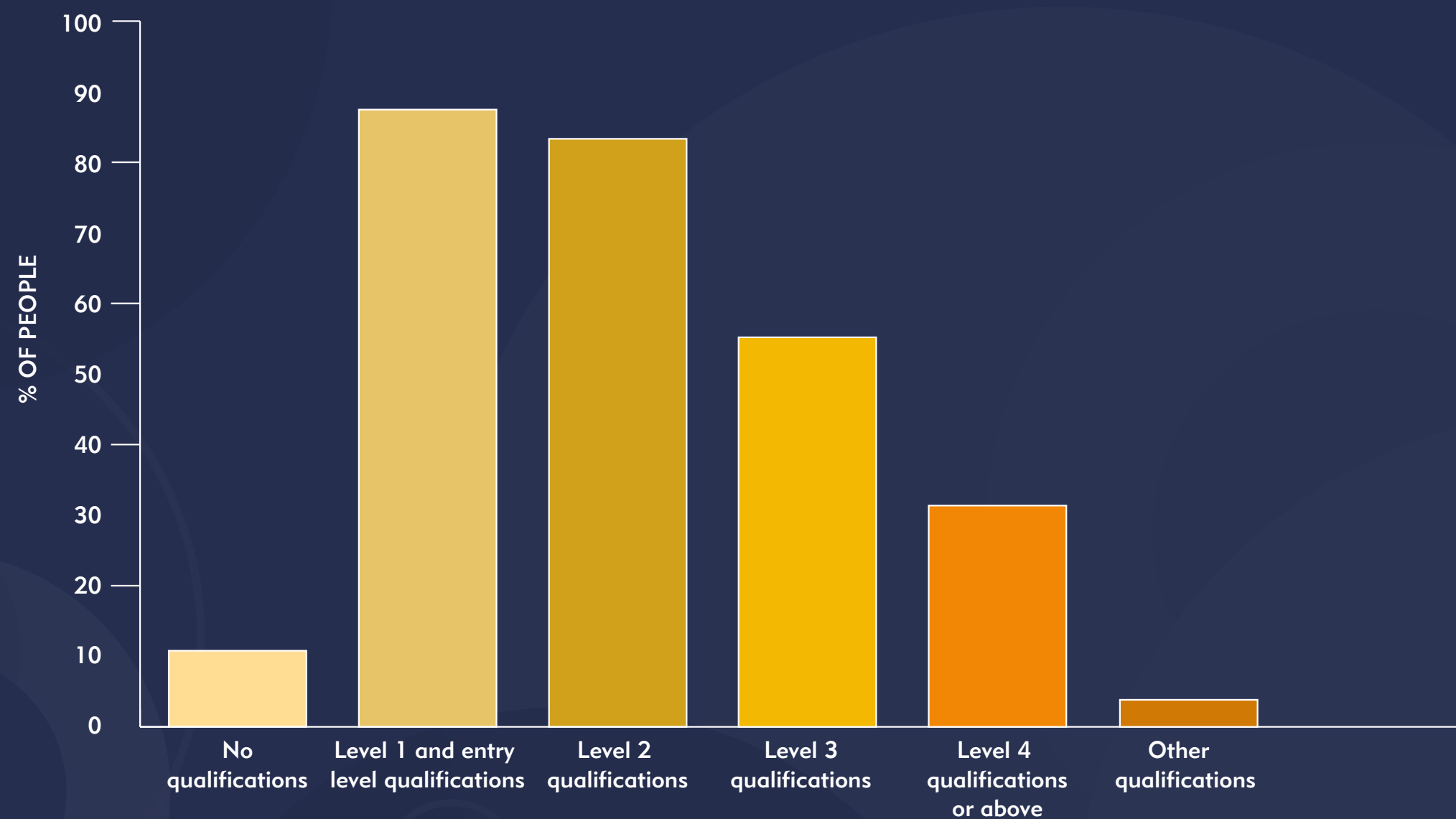

Source: ONS - 2021 Census North West Region.

PERFECTLY LOCATED FOR BUSINESS

Wigan 100 is situated within easy reach of Junctions 25 and 26 of the M6 and within just a few minutes of Wigan town centre.

Major motorway and road networks including the M6, M61, M62, M58 and A580 (East Lancs Road) are within easy reach.

Wigan is situated on the West Coast main rail line providing regular services to London, Manchester and Liverpool.

Local occupiers include:

HEINZ *Makita*
arrowxl

POSTCODE: WN5 0JZ

Local occupier - Makita

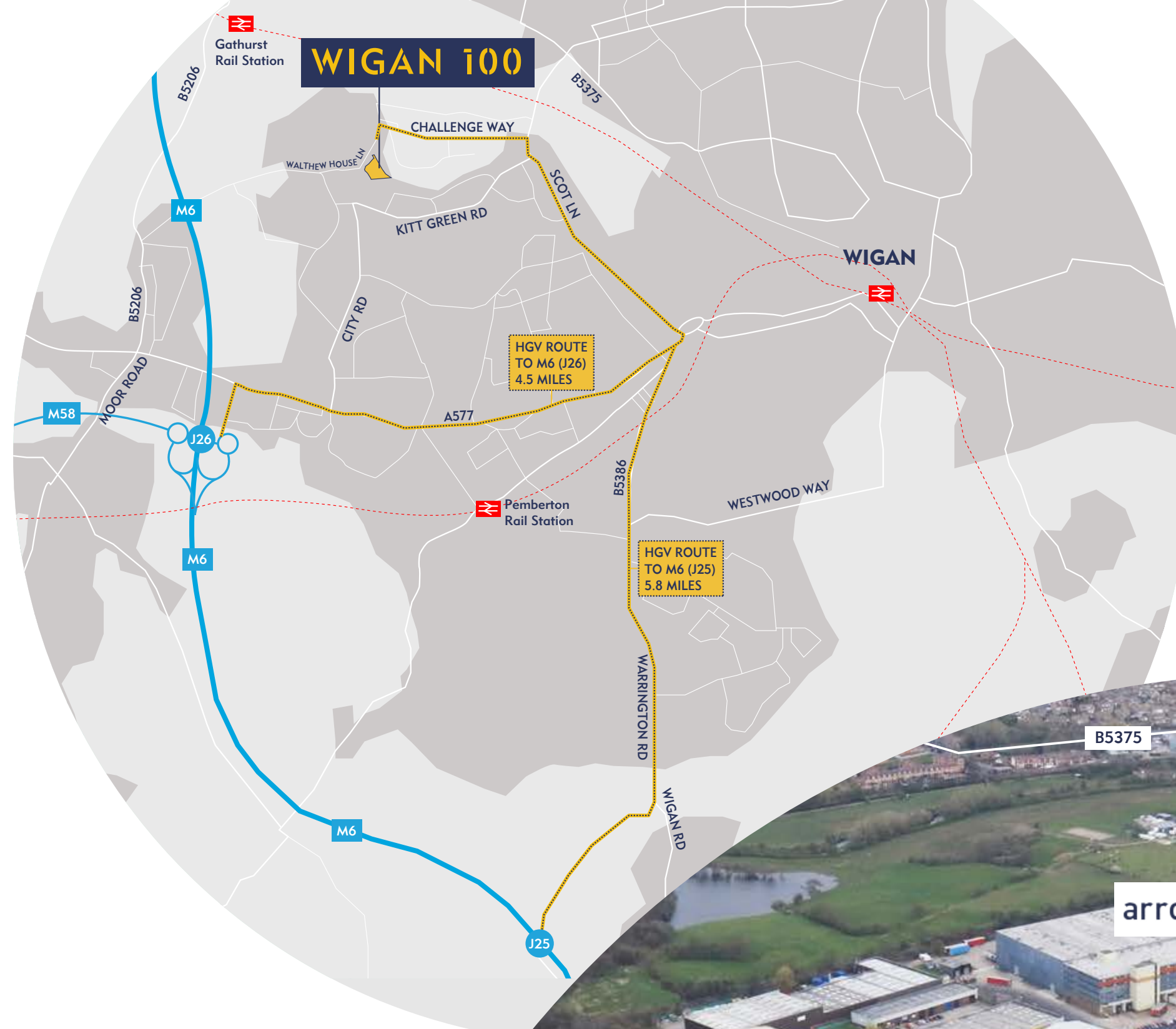

Local occupier - Heinz



STRATEGICALLY POSITIONED

POSTCODE: WN5 0JZ



DRIVE TIMES

Wigan Town Centre	2 miles	10 mins
Liverpool	20 miles	30 mins
Manchester	27 miles	35 mins
Birmingham	92 miles	1 hr 30 mins



12 MILLION

Over 12 million of the UK population live within a 90 minute drive time.

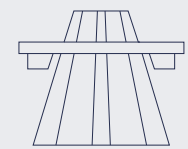

MOTORWAYS

M6 (J26)	2 miles	5 mins
M58	2 miles	6 mins
M61	7 miles	16 mins
M62 (J10)	12 miles	18 mins
M56 (J9)	19 miles	24 mins

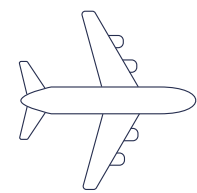

AIRPORTS

Manchester	29 miles	30 mins
Liverpool	30 miles	35 mins
East Midlands	94 miles	1 hr 40 mins
Birmingham	102 miles	1 hr 40 mins

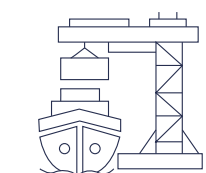

PORTS

Birkenhead	26 miles	40 mins
Liverpool	22 miles	35 mins
Immingham	131 miles	2 hrs 10 mins
Teesport	144 miles	2 hrs 40 mins

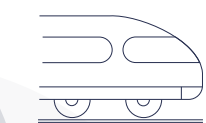

RAIL FREIGHT

Trafford Park	25 miles	30 mins
Widnes	25 miles	30 mins
Port Salford	24 miles	35 mins
West Midlands Interchange	72 miles	1 hr 15 mins

Source: Google

HGV DRIVETIMES

- 0-90 Minutes
- 90-180 Minutes
- 180-270 minutes

Drive times are approximate.

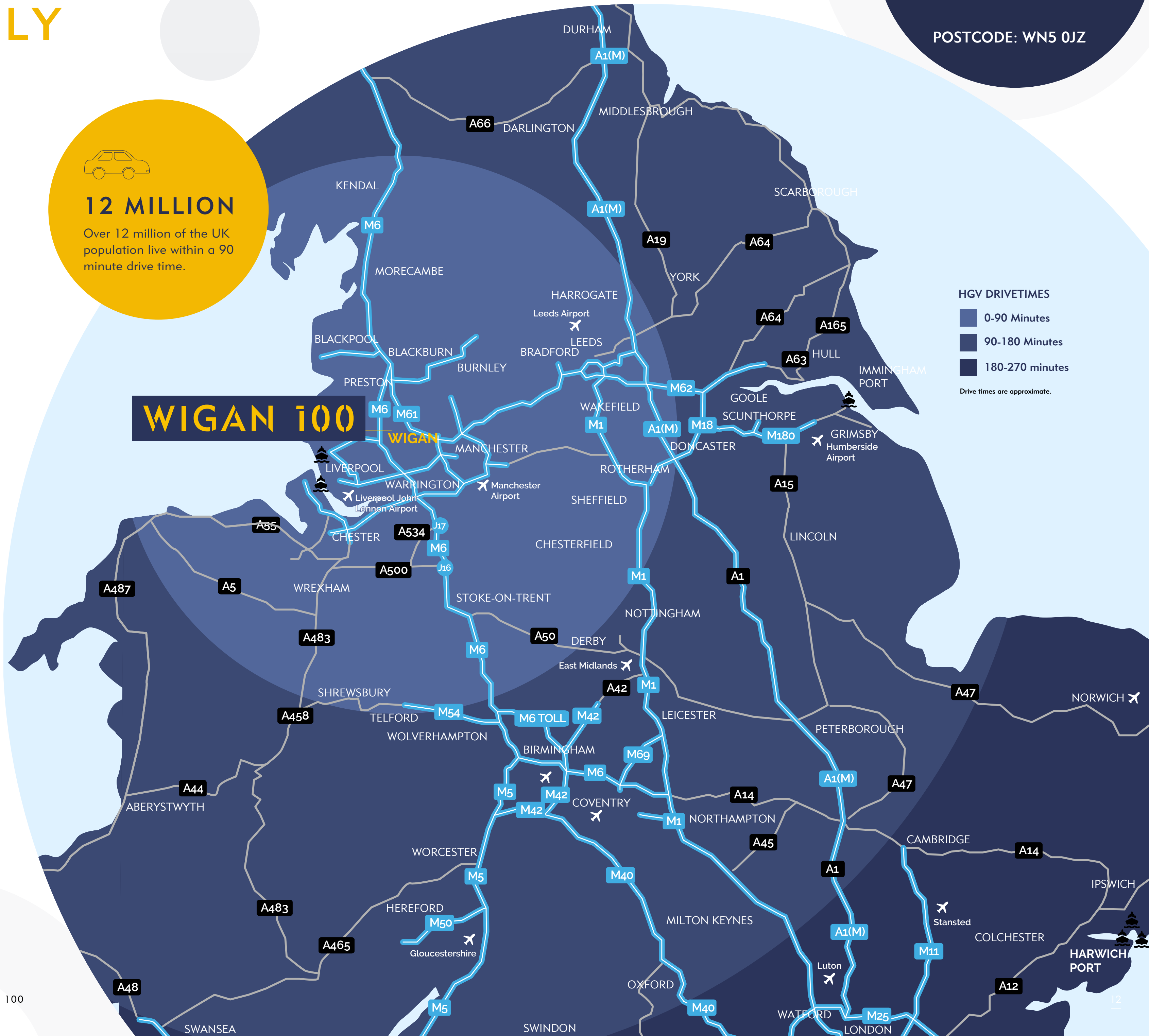

SUSTAINABILITY AT ITS HEART



BREEAM IN USE

The unit has achieved BREEAM "Excellent" certification. Hillwood and our consultants are committed to including the maximum amount of sustainable enhancements possible at each of our schemes.



ENERGY PERFORMANCE (EPC)

The unit has achieved an EPC "A" Rating.

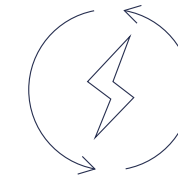

ENERGY EFFICIENT HEATING & COOLING

Variable Refrigerant Flow (VRF) heating / cooling system with internal ceiling concealed fan coil units fed from external air source heat pump to the offices, and efficient local electric heaters to ancillary areas.

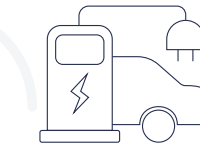

ELECTRIC VEHICLE (EV) CHARGING

The unit provides EV charging spaces, as well as providing ducting to enable further spaces to be constructed in the future.



ENERGY EFFICIENT LIGHTING

Energy efficient LED lighting is provided to the offices, operated by PIR sensors and daylight dimming sensors.



SOCIAL WELLBEING

Wigan 100 combines outdoor wellbeing areas with open plan internal areas with natural daylight to offer staff a pleasant and natural environment. Nearby pedestrian routes offer access to public transport and the unit is within walking distance to the town centre.

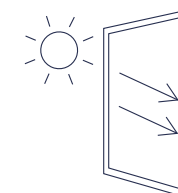

NATURAL DAY-LIGHT

10% of the roof panels across the warehouse are translucent, providing plenty of natural day-light.

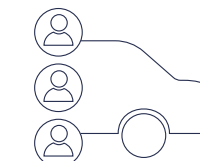

CAR SHARING

The Landlord can mark spaces in accordance with an occupiers bespoke car sharing scheme.

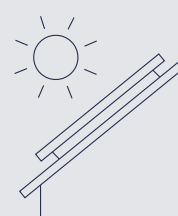
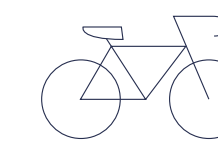

PHOTO-VOLTAIC (PV) PANELS

A provision of PV panels has been provided under the base build, whilst the roof is structurally designed to support panels across the entirety so the occupier can add more as they wish.



CYCLE PARKING

Covered cycles spaces have been provided.

HILLWOOD

Hillwood is a leader in developing and acquiring high-quality, sustainable industrial and logistics properties across the UK, Europe, U.S., and Canada. Within these core markets we have delivered more than 230 million sq ft combined across 12,500 acres.

Our UK operational experience spans more than two decades and our innovative approach to master planning, commercial development, and property acquisitions has led to exciting partnerships with landowners and occupiers. Along the way, we've stuck to our belief that we are most successful when delivering creative solutions and long-term value for our partners and customers.

Most importantly, our private ownership and depth of capital allows us to move quickly to identify opportunities, whilst applying the hands-on approach you would expect from a long-term trusted partner. We make your business, our business.

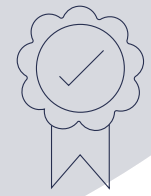

BEST IN CLASS

Development team, technical team, and consultants.

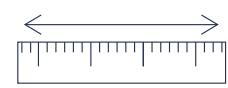

5M SQ FT

Committed from 2025 onwards.

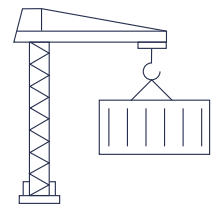

LIVE PROJECTS

In every region of the UK.



SUSTAINABLE

Developing to BREEAM "Excellent" and Net Zero.



FOCUSED

Global reach, focused home team.



AGILE

Private ownership and capital allows quick decisions.

RECENT OCCUPIERS



OUR AWARDS



www.hillwooduk.com

"PROACTIVE, PROFESSIONAL, AND PASSIONATE"

"Hillwood led all development activities having introduced the site to CROWN and achieved a very fast track programme to meet our operational targets. They have at all times been proactive, professional, and passionate about delivering the project to our requirements and they are worthy of positive recognition for this major project delivery, which we have acquired on a Freehold basis."

Richard Ford

Director - Project Management and Engineering and Real Estate
Crown Packaging Manufacturing UK Ltd.



Lighting Park, Huntingdon



Crewe 335, Crewe



Central Approach, Bristol



FURTHER INFORMATION

PLANNING

Detailed planning consent for unrestricted B2 and B8 employment use [Planning References - Outline planning: A/22/93842/OUTMAJ / Reserved matters: A/24/97573/RMMAJ).

RENT

Please contact our retained agents for further information.

TENURE

The premises are available by way of a new lease and may be considered for sale, subject to occupier interest.

TIMING

Available immediately.



WIGAN 100

WALTHEW HOUSE LANE,
WIGAN WN5 0JZ

CONTACT

Please contact the retained agents:



BRADLEY NORTON
07870 393 145
Bradley.Norton@knightfrank.com

ROB TILLEY
07973 622 837
Rob.Tilley@knightfrank.com



PAUL COOK
07793 119 221
Paul.J.Cook@cbre.com

STEVE CAPPER
07825 862 770
Steve.Capper@cbre.com



IMPORTANT NOTICE Knight Frank and CBRE give notice to anyone who may read these particulars as follows: 1. These particulars are prepared for the guidance only of prospective purchasers. They are intended to give a fair overall description of the property but are not intended to constitute part of an offer or contract. 2. Any information contained herein (whether in the text, plans or photographs) is given in good faith but should not be relied upon as being a statement or representation of fact. 3. Nothing in these particulars shall be deemed to be a statement that the property is in good condition or otherwise nor that any services or facilities are in good working order. 4. The photographs appearing in this brochure show only certain parts and aspects of the property at the time when the photographs were taken. Certain aspects may have changed since the photographs were taken and it should not be assumed that the property remains precisely as displayed in the photographs. Furthermore no assumptions should be made in respect of parts of the property which are not shown in the photographs. 5. Any areas, measurements or distances referred to herein are approximate only. 6. Where there is reference in these particulars to the fact that alterations have been carried out or that a particular use is made of any part of the property this is not intended to be a statement that any necessary planning, building regulations or other consents have been obtained and these matters must be verified by any intending purchaser. 7. Descriptions of a property are inevitably subjective and the descriptions contained herein are used in good faith as an opinion and not by way of statement of fact. Published February 2025. Updated March 2026.